

LX4070

70"x40"x22.5"



GENERAL SPECIFICATIONS:

Tub Size	70"x40"x22.5"
Bathing Well:	Length: 63" top / 45" bottom Width: 43" top / 22" bottom Depth at overflow: 17"
Average Fill:	50 gal to account for body
Maximum Fill:	75 gal to overflow
Electrical Requirement:	1-20 amp/115 GFCI outlet

All LX tubs are manufactured with 0.125" 100% acrylic, the thickest in the industry: Pre-leveled and framed to make installation quicker and easier. Tubs are freestanding and require no additional framing or costly installation labor. Bathtub bases are made with a solid wood base and structural foam that provides support, reduces noise, and insulates.

FSTP SKU KEY:

FSTP4070SWH

Color: White | Biscuit | Bone
Model #: Soaker | Whirlpool | Air

*Please specify left or right hand drain and motor placement
LHD - Left Hand Drain
RHD - Right Hand Drain
LHM - Left Hand Motor

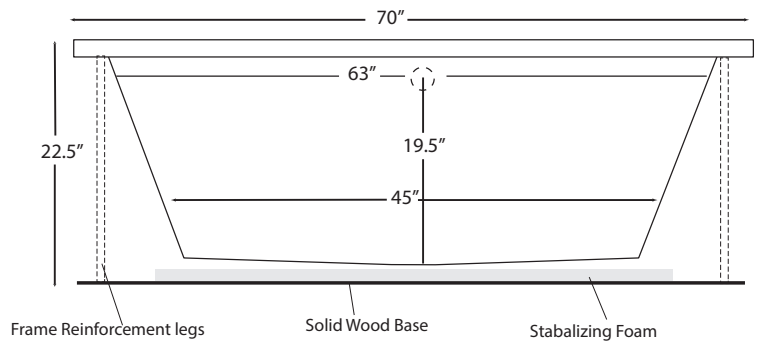
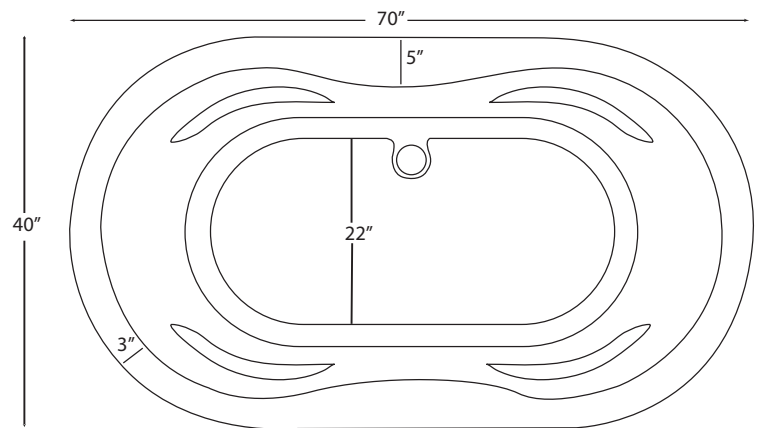

INSTALLATION: Height measurement is inclusive of wood and foam framing. All measurements are +/- 1/2" and are subject to change without notice. Drawing shows recommended pump location as well as approximate location of frame reinforcement legs. Please measure tub before building deck. Data herein supercedes all previous data prior to date shown below.

